

Installation And Operation Instruction

Reactor Tank Bottom Discharge Valve
- ZPL100 Series



Products Overview

The bottom discharge valve is primarily use for discharging materials from the bottom of reactors, tanks, and other containers. This valve is connected to the container bottom flange, effectively eliminating any residual medium typically found at the container outlet. As a specialized cutting valve predominantly employed in various storage containers' bottom. Its sleek streamlined design of the valve body flow channel and spherical single seat valve core type facilitate smooth medium flow. Widely applied in polymerization reactions, chemical fiber production, food processing, fermentation processes, and other industries; it also proves to be an ideal choice for slurry material and high-density fluid applications. When selecting valves from this series, it is crucial to consider factors such as temperature, pressure levels, adhesion properties, corrosiveness of the medium within the storage container to optimize performance under different operating conditions.

Variety & Feature Of ZPL100 Valves

Fluorine-lined downward-opening discharge valve: ZPL170F (corrosion-resistance ,Anti-impede)

Metal downward-opening discharge valve: ZPL170Y (Anti-impede)

Fluorine-lined upward-opening discharge valve: ZPL180F (corrosion- resistance, Anti-impede, Anti-scouring,anti-crystallization,Anti-blocking)

Metal upward-opening discharge valve: ZPL180Y (Anti-impede, Anti-scouring,anti-crystallization,Anti-blocking)

Fluorine-lined horizontal discharge ball valve: ZPR740F (corrosion-resistance ,Anti-impede)

Fluorine-lined diagonal discharge ball valve: ZPR741F (corrosion-resistance ,Anti-impede; suitable for the bottom of an inverted U-shaped reactor)

Metal horizontal discharge ball valve: ZPR780F (Anti-impede)

Metal diagonal discharge ball valve (Anti-impede; suitable for the bottom of an inverted U-shaped reactor)

The selection can be made by users based on their specific operating conditions, including pressure differential, temperature, medium state, and installation method, as well as their requirements for leakage volume

Structure Of Fluorine-Lined Upward-Opening Discharge Valve(ZPL180F)

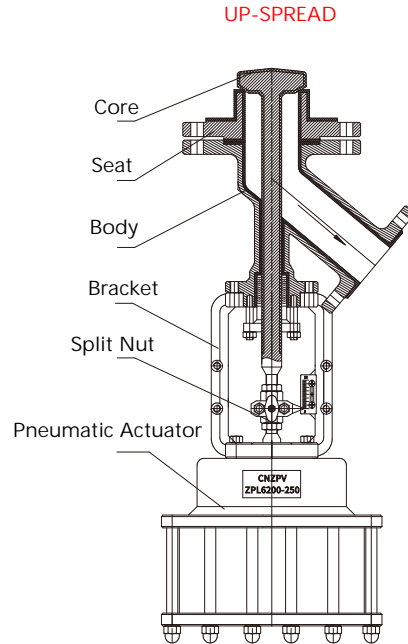

Application And Characteristics

1. ZPL170 downward-opening Discharge Valve features a valve disc that operates within the valve body, requiring it to overcome the force of the medium when closed. The closing force surpasses the opening force, making this valve suitable for reactors with non-crystallizing media.
2. ZPL180 upward-opening Discharge Valve is designed with a tapered valve disc that moves outside the valve body and towards into the inner of reactor. When opened, it needs to counteract the force exerted by the medium. The opening force exceeds the closing force, making this up-open valve use for reactors equipped with stirrers and prone to crystallization.

The Features:

1. Our bottom discharge valve is compatible with various media, and for corrosive substances, can use fluorine-lined valve to meet the requirements of strong corrosion applications.
2. A bottom guide is employed to prevent material stack and crystallization, while also reducing the run-length of the valve core to prevent deformation of the valve shaft.
3. The discharge gate and container are positioned at a 45°-degree angle with a curved transition, can makes facilitating smoother material discharge. Additionally, it effectively increases the distance between the container bottom and discharge gate, resolving installation issues related to concave outlet ends.
4. Utilized a multi-spring aluminum air-cylinder, to reduce size and weight of cylinder at the bottom of the container, .By adjusting wire range and spring length, output force can be increased or decreased to meet different product specifications requirements.
5. The air-cylinder allows for single-acting or double-acting functions by adding or removing springs respectively. Furthermore, changing spring installation direction enables positive or negative actions for up-open or down-open bottom discharge valve.
6. An external PT100 explosion-proof temperature sensor can be added for online temperature monitoring as well as 4-20mA remote monitoring in control room to regulate material temperature within containers. effectively solving the safety concerns during material reactions.
7. The valve can be equipped with limit switches for remote position display purposes. The equal percentage curve processing on its valve core combined with a positioner can achieve the regulation function.
8. Adding a Corrugated pipe structure provides dual protection against hazardous corrosive media.

Materials For Main Parts

Body Material	wCB、LCB、304、316、316L
Core Material	410、304、316、316L
Seat Material	304、316、316L (+PTFE/PPL)
Stem Material	17-4PH 304、316、316L
Liner Material	F(F46)、A (PFA)
Bellows Material	PTFE、316L
Valve Type	Upward-opening、Downward-opening、Bellows Type、Jacket insulation
Temp. Range	-40 to 300

Leakage Level(ANSI)	ANSI B16.104 Grade VI
Flow Characteristic	Linear, EO%,ON/OFF,Cut-off
Ends	Flang(RF/FM/RJ)、Welded type
Flange Connection Standard	HG20592-2009,ANSI B16.5
Available Actuators	Pneumatic Diaphragm Type(ZP6100)
	Pneumatic Piston Type(ZP6200)
	Electric Type

When dealing with highly corrosive mediums or grain-like mediums, it is advisable to selecting for an fluorine-lined discharge valve.

When utilizing a stirrer in the container, careful attentioned to the distance of the stirrer to the bottom.
 If this distance is insufficient, selecting a downwrod-opening discharge valve would be recommended.

Outer Size Of ZPL170/ZPL180

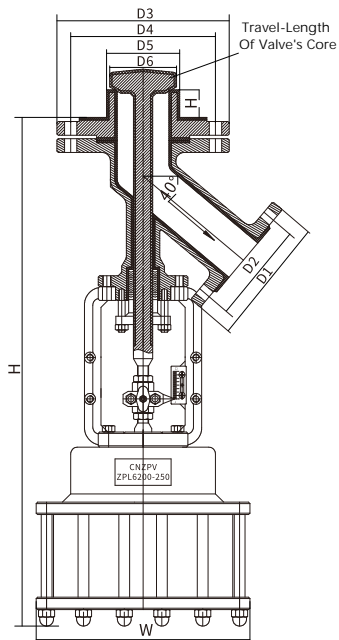

DN	Lower Flange (PN16)		Top Flange (PN6)		Lower Flange (PN16)		Sealing Seat		H	W	Travel-Length
	D1	D2	D3	D4	D3	D4	D5	D6			
40	150	110	130	100	150	110	38	35	595	245	25
50	165	125	140	110	165	125	48	45	610	245	25
65	185	145	160	130	185	145	62	59	725	320	40
80	200	160	190	150	200	160	77	74	745	320	40
100	220	180	210	170	220	180	97	94	770	320	40
125	250	210	240	200	250	210	122	119	890	430	60
150	285	240	265	225	285	240	147	144	920	430	60
200	340	295	320	280	340	295	197	194	950	430	60

Note Please!

Due to the connection standards of the manufacturers are different, the size of the sealing seat will not same, please check with the details of the selection precautions before place an order.

(The size of the product is subject to the physical object)

Precautions Before Ordering

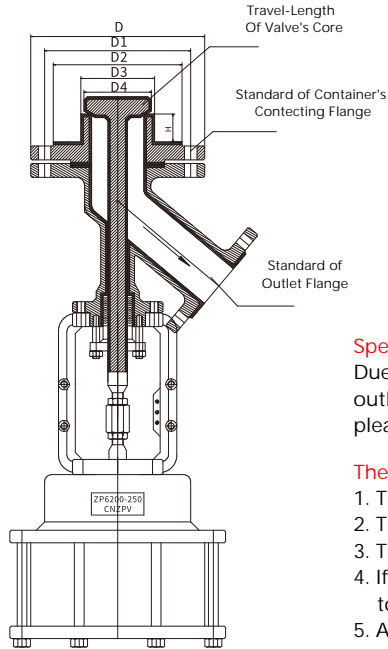

Reactor's Sectional Drawing

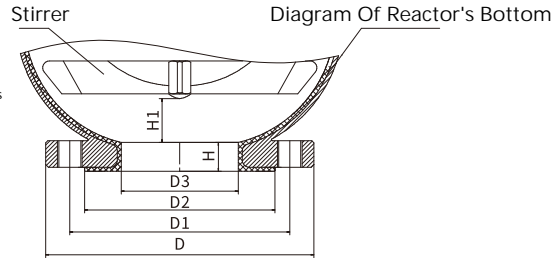

Special Note:

Due to the unique design of the upward-opening discharge valve, the size of the outlet gate at the bottom may differ for each manufacturer. Therefore, please provide us with the specific dimensions of yours before placing an order.

The Key Dimensions:

1. The Flange Connection Standard for reactor's Bottom (D1).
2. The diameter of outlet gate (D3).
3. The height from the plane of outlet gate to the bottom of reactor (H).
4. If with a stirrer, kindly indicate the height from the bottom of your reactor to the stirrer (H1).
5. Any special requirements regarding stroke and installation method should be noted.