

Installation And Operation Instruction

Fluorine-Lined Cut-off Ball Valve
-ZPR700 Series



Products Overview

The ZPR700 series of fluorine-lined cut-off valves are equipped with a layer of fluoroplastic coating on both the valve body and valve core surfaces that come into contact with the fluid. This effectively isolates the corrosive media from any metal contact, providing excellent protection against corrosion for all metal materials. These valves exhibit exceptional sealing performance, responsive action, precise flow characteristics, and find extensive applications in environments involving strong corrosive media such as acids, alkalis, salts, as well as volatile and penetrative gas and liquid media.

Fluorine-Lined O-Shape Cut-off Ball Valve

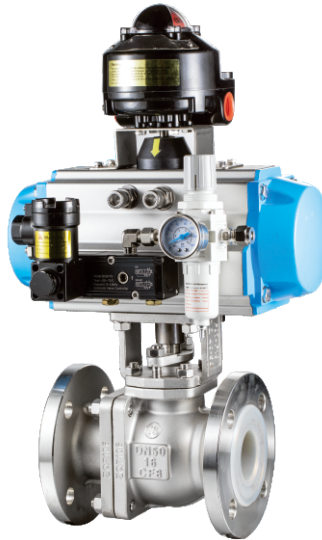

05

Fluorine-Lined O-shape Ball Valve-ZPR710F

Application And Characteristics

The ZPR710F Fluorine-lined O-shape Cut-off Ball Valve features a valve body and inner parts that come into contact with the fluid, which are lined with fluoroplastic through a high-temperature molding process. Additionally, the inner cavity of the metal valve body undergoes gear machining to ensure complete bonding between the lining material and metal, thereby enhancing both service life and performance. This valve effectively isolates corrosive media from contacting the valve body while preventing any corrosion of metallic materials within it. With excellent sealing performance, sensitive action, precise flow characteristics, it finds extensive applications in environments involving strong corrosive media such as acids, alkalis, salts as well as volatile and penetrative gas or liquid media.

1. Corrosion-resistant: It can withstand the corrosion of various media, including concentrated nitric acid and aqua regia.
2. High flow capacity with unrestricted medium flow direction.
3. Excellent sealing performance: Utilizes a combination structure of imported and domestic V-shape packing gland to ensure zero external leakage.
4. Minimal leakage due to the soft sealing with fluoroplastic of the valve core and seat.

Product Structure

The fluorine-lined ball valve is available in two configurations: Floating ball and Fixed ball.

The floating ball structure is suitable for valves with a diameter of 250mm or smaller, while the fixed ball structure is designed for valves with a diameter of 250mm or above.

This non-directional valve can be installed at any angle but welding on the pipeline is strictly prohibited.

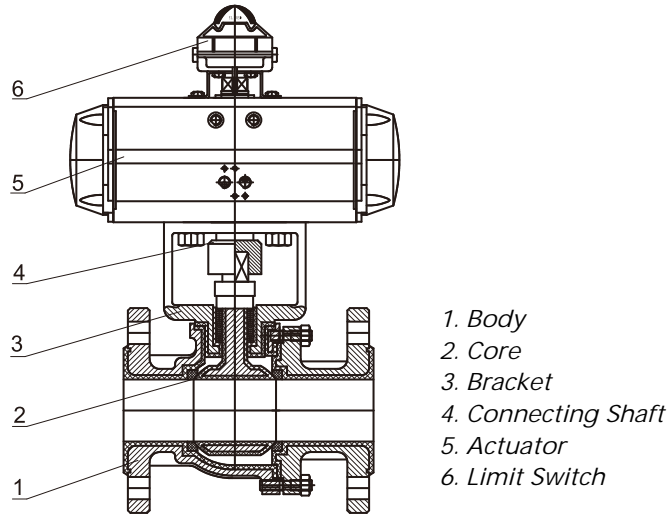

Fluorine-Lined O-Shape Cut-off Ball Valve

Technical Parameters/Performance Indicators

Body/Bonnet Material	WCB, LCB, SS304, SS316, SS316L	Leakage Level	ANSI B16.104 Grade VI
Core Material	304, 316, 316L, TA2, HC	Flow Characteristic	EQ%, Linear, Cut-off
Inner-Lined Material	F40(ETFE), F46(FEP), PTFE(F4), PFA	Ends	Flang(RF/FM)
Seat/Packing Material	PTFE	Flange Connection Standard	HG20592-2009, ANSI B16.5
Valve Type	O-shape, V-shape, Tee(Three-way), Discharge	Actuator (Linear Motion Type)	Pneumatic Piston Type
Temp. Range	-40 to 160		Electric Type

As: chloroacetic acid, liquid chlorine, chlorine gas, bromine and other strong corrosive material, the selection of lining materials must be carefully.

Fluid's Temp	Medium Characteristics	Location	Lining Material	Forming Process
80	General Medium	General Position	F40(ETFE)	Injection Processing
120	Strong Corrosive Medium	Special Position	F46(FEP)	Mould Processing
160	Strong Corrosive Medium	Special Position	PFA	Mould Processing(With Bracket)

Fluorine-Lined O-Shape Cut-off Ball Valve

Actuator Options Table

Nominal Diameter	Pneumatic Actuator (Gears/Racks)		Electric Actuator	Rated Flow Coefficient (CV)
	Duplex Acting	Single Acting		
DN15	AT50DA	AT63SR	05	20
DN20	AT50DA	AT63SR	05	38
DN25	AT63DA	AT75SR	05	72
DN32	AT75DA	AT90SR	10	93
DN40	AT90DA	AT100SR	10	145
DN50	AT100DA	AT115SR	15	230
DN65	AT115DA	AT125SR	20	406

Nominal Diameter	Pneumatic Actuator (Gear/Rack)		Electric Actuator	Rated Flow Coefficient (CV)
	Duplex Acting	Single Acting		
DN80	AT125DA	AT145SR	40	576
DN100	AT145DA	AT160SR	50	940
DN125	AT160DA	AT190SR	80	1400
DN150	AT190DA	AT210SR	100	2050
DN200	AT210DA	AT240SR	160	3600
DN250	AT270DA	AT300SR	200	5150
DN300	AT300DA	AT350SR	250	7350

Fluorine-Lined O-Shape Cut-off Ball Valve

Outer Size

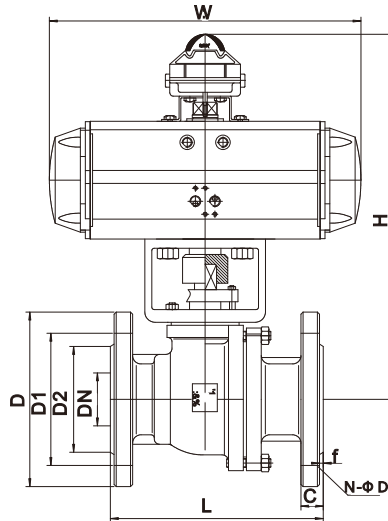

DIMENSION UNIT: MM

Nominal Diameter	L	H	W	ATSR
DN20	140	350	168	AT63SR
DN25	150	380	219	AT75SR
DN32	165	400	249	AT90SR
DN40	180	435	274	AT100SR
DN50	200	450	315	AT115SR
DN65	220	500	355	AT125SR
DN80	250	540	417	AT145SR
DN100	280	585	452	AT160SR
DN125	320	640	540	AT190SR
DN150	360	690	585	AT210SR
DN200	400	780	685	AT240SR

Nominal Diameter	D	D1	D2	C	f	N-φ D
DN20	105	75	55	18	2	4-φ 14
DN25	115	85	65	18	2	4-φ 14
DN32	140	100	75	18	2	4-φ 18
DN40	150	110	85	18	2	4-φ 18
DN50	165	125	100	18	2	8-φ 18
DN65	185	145	120	18	2	8-φ 18
DN80	200	160	135	20	2	8-φ 18
DN100	220	180	155	20	2	8-φ 18
DN125	250	210	185	22	2	8-φ 18
DN150	285	240	210	22	2	8-φ 22
DN200	340	295	265	24	2	12-φ 22

(The size of the product is subject to the physical object)

Installation Notice

1. Before installation, carefully inspect the valve (Tag No., type, diameter, pressure, material, etc.) to ensure compliance with the required specifications. If the product is labeled with a flow direction indicator on the valve's body that equipped with the pipeline flow direction. If without indicator, no further consideration of flow direction is necessary.
2. The valves should be vertically installed on horizontal pipelines, with the actuator positioned at the top. It is advisable to avoid installing them at an angle.
3. When connecting pipes and sealing faces are made of metal materials, it is essential to use a fluoroplastic sealing gasket; otherwise, premature damage and leakage may occur on the valve's sealing face. To ensure uninterrupted production during maintenance or failure situations, consider setting up a bypass.
4. The product has been meticulously designed and manufactured according to relevant parameters specified in technical specifications. In case there are changes in usage parameters, please promptly contact our company (special requirements should be communicated prior to placing an order). The product undergoes thorough testing and adjustment before leaving our factory; if possible before installation, conducting additional tests on sealing and external leakage is recommended. Product accessories have already been adjusted to their optimal positions and should not be arbitrarily altered.
5. During system or pipeline flushing and testing procedures, ensure that the valve remains fully open.

Repair & Maintenance

1. All fluorine-lined control valves are used in highly corrosive media, and it is essential to wear appropriate protective equipment and strictly adhere to operational procedures during maintenance and repair activities. This will help prevent accidents during disassembly and ensure safety.
2. During maintenance and repair tasks, the operator should position themselves on the side of the product rather than operating from the front. Additionally, for toxic, flammable, explosive media, it is necessary to maintain a safe distance.
3. In case of seal leakage, shut off the signal source to allow automatic valve closure. If there is no further leakage after adjusting the signal drift, it indicates that signal adjustment is required. If leakage persists even after adjustment, shut down the pipeline and inspect for any damage to the seal face. Clean impurities if no damage is found; otherwise replace the valve instead of using it.
4. If packing leakage occurs, tightening the cover nut (3-5 turns) usually resolves this issue. However, if tightening by 5 turns or more still results in leakage, work must be immediately stopped. Close off the pipeline and inspect whether there are cracks or corrosion in the valve body. It is strictly prohibited to replace packing under pressure for fluorine-lined control valves installed on pipelines carrying toxic substances or those prone to flammability/explosiveness/strong corrosion.
5. For working conditions where crystallization of soft materials may occur frequently, special attention should be given to checking for blockages caused by crystallization in order to prevent flow reduction and pressure decrease.